

## UV100E Ultraviolet Systems

UV100E1043 AND UV100E2009 AIR TREATMENT SYSTEMS

UV100E3007 SURFACE TREATMENT SYSTEM

### PRODUCT DATA



### APPLICATION

When installed in forced air heating and cooling systems, the UV100E Ultraviolet Systems kill airborne or surface micro-organism contaminants like mold and bacteria.

The UV systems use patented SmartLamp™ control technology that monitors the HVAC system to operate the lamps only when needed. This technology extends bulb life up to five times and reduces power consumption, lowering operating costs. The UV systems also include local diagnostics with the SmartLamp™ LED and reset capability.

### FEATURES

- SnapLamp™ features replacement lamp handle with detachable replacement bulb, UC18W or UC36W, to make replacement more economical.
- SmartLamp™ Control Algorithm determines optimal UV lamp usage.
- SmartLamp™ LED shows bulb life and replacement.
- Reduced power consumption and extended bulb life.
- Communicates with other home appliances through Envirocom™ three-wire communications bus.
- Automatic brownout and high temperature protection for UV lamps.
- Return air models supplied with integrated airflow sensor to monitor air flowing through ductwork.
- Dual-purpose reset button:
  - Commands lamp on with a single one-second push.
  - Resets internal lamp run-time timer after bulb replacement with extended five-second hold.
- UV-C light kills airborne bacteria and surface mold.
- UV lamp does not produce ozone.
- Easy lamp maintenance with quick, easy bulb replacement.
- Sealed unit prevents accidental installer/homeowner contact with high voltage and ultraviolet rays.
- Safe design prevents lamp from lighting unless base is correctly mounted on HVAC duct.
- Lamp light indicator to safely view lamp operation.
- Power cord that plugs into 120 Vac electrical outlet.
- Five-year limited warranty.

### Contents

Application/Features .....	1
Specification/Ordering Information .....	2
Installation .....	3
Checkout .....	7
Troubleshooting and Service/Maintenance .....	8
Parts List .....	11



## SPECIFICATIONS

### IMPORTANT

*This product is tested and calibrated under closely controlled conditions and some minor differences in performance can be expected if those conditions are changed. The specifications in this publication do not include normal manufacturing tolerances; therefore, an individual unit may not exactly match the listed specifications.*

### TRADELINER<sup>®</sup> Models available:

The UV100E Ultraviolet System is available in three models: a single-lamp air treatment system, a dual-lamp air treatment system, and a surface treatment system.

- UV100E Air Treatment Systems (single-lamp and dual-lamp) are mounted in the return air duct of an HVAC system. The single-lamp unit has moderate efficiency and the dual-lamp unit has high-efficiency performance against airborne bacteria in return air applications.
  - *Without Envirocom hooked up:* monitors air flowing through ductwork using supplied airflow sensor mounted to backside of unit. Operates lamp when air is flowing (120 fpm minimum), leaving lamp on for 40 minutes after airflow stops. If airflow resumes during the 40 minutes, the timer resets to 40 minutes. When no airflow is detected for 40 minutes, the lamp turns off until the next occurrence of airflow.
  - *With Envirocom hooked up:* monitors thermostat load information instead of using airflow sensor to operate on and off.
- UV100E Surface Treatment System is mounted in the supply-side air duct or downstream or upstream from air conditioner evaporator coils in HVAC system. It reduces mold growth and spores on duct surfaces, coils and drip pans.
  - Does not use an airflow sensor.
  - *Without Envirocom hooked up:* operates steady on/off cycle: lamp operates three hours on, three hours off for a total two-year life cycle.
  - *With Envirocom hooked up:* after initial three hours run time, operates three hours on and three hours off during times when the evaporator A-coil may be exposed to moisture, including when the control sees a cooling call and for 30 days after the last cooling occurred. This operation extends the bulb life beyond two years.

### Efficiencies:

- UV100E Surface Treatment System: Kills up to 99.9% of mold on system cooling coils.
  - Test performed in a test duct showed reduction in colony-forming aspergillus niger mold spores when surface was irradiated at a distance of 18 in. for three hours in still air, using new lamps.
- UV100E Air Treatment System (dual-lamp): Kills up to 87% of airborne bacteria passing by the system.
  - Test showed single-pass kill-rate of serratia marcescens bacteria in a clean metal 12 in. x 25 in. duct at an airflow rate of 2000 cfm using new lamps.
- UV100A Air Treatment System (single-lamp): Kills up to 70% of airborne bacteria passing by the system.
  - Test showed single-pass kill-rate of serratia marcescens bacteria in a clean metal 12 in. x 25 in. duct at an airflow rate of 2000 cfm using new lamps.

### Envirocom<sup>™</sup> Communications Capabilities:

- Communicates with homeowner through three-wire communication bus using 24 Vac thermostat connections.
  - *Hooked up to single-lamp and dual-lamp Air Treatment System:* uses thermostat load information instead of airflow sensor.
  - *Hooked up to Surface Treatment System:* uses thermostat load information to operate during times evaporator A-coil may be exposed to moisture to extend bulb life beyond two years.
- Sends messages to communicate reset and receives remote reset, when available.
  - Lamp change indication cannot be reset by cycling power.
  - When Envirocom is transmitting messages, shows flashing green Envirocom LED on bottom of unit.

### Electrical Ratings:

Voltage Rating: 120 Vac, 60 Hz.  
Current and Power Ratings:

Model	Input Power (A)	Bulb Wattage (W)
UV100E1043 Air Treatment System (single lamp)	0.46	18
UV100E2009 Air Treatment System (dual lamp)	0.62	36 (each bulb)
UV100E3007 Surface Treatment System	0.74	36

## ORDERING INFORMATION

When purchasing replacement and modernization products from your TRADELINE<sup>®</sup> wholesaler or distributor, refer to the TRADELINE<sup>®</sup> Catalog or price sheets for complete ordering number.

If you have additional questions, need further information, or would like to comment on our products or services, please write or phone:

1. Your local Honeywell Automation and Control Products Sales Office (check white pages of your phone directory).
2. Honeywell Customer Care  
1885 Douglas Drive North  
Minneapolis, Minnesota 55422-4386

In Canada—Honeywell Limited/Honeywell Limitée, 35 Dynamic Drive, Toronto, Ontario M1V 4Z9.

International Sales and Service Offices in all principal cities of the world. Manufacturing in Australia, Canada, Finland, France, Germany, Japan, Mexico, Netherlands, Spain, Taiwan, United Kingdom, U.S.A.

**Temperature Ratings:**

Ambient Temperature Range: 30°F to 104°F (-2°C to 40°C).  
 Bulb Temperature Range (In Moving Air): 30°F to 140°F  
 (-2°C to 60°C).

**Relative Humidity:**

Up to 95% rh, non-condensing.

**Dimensions:**

See Fig. 3.

**Approvals:**

Underwriters Laboratories: File no. E223009  
 The health aspects associated with the use of this product and its ability to aid in disinfection of environmental air have not been investigated by UL.

## INSTALLATION

### When Installing this Product...

1. Read these instructions carefully. Failure to follow them could damage the product or cause a hazardous condition.
2. Check the rating given in the instructions and on the product to make sure the product is suitable for your application.
3. Installer must be a trained, experienced service technician.
4. After installation is complete, check out product operation as provided in these instructions.



### **! WARNING**

**UV Light Hazard.**  
**Harmful to bare skin and eyes.**  
**Can cause temporary or permanent loss of vision.**  
 View illumination only through lamp light indicator on lamp handle.  
 To prevent exposure to ultraviolet light, disconnect power to ultraviolet system before servicing any part of heating and air conditioning system.  
 Do not mount device in location that allows ultraviolet light to be seen after installation.  
 Do not attempt to bypass duct mount switch.

### **! CAUTION**

**Personal Injury Hazard.**  
**Power supply can cause electrical shock.**  
 Disconnect power supply before beginning installation.  
 Do not open base unit or lamp handle; there are no user-serviceable components inside.

### Selecting Mounting Location



### **CAUTION**

**Equipment Damage Hazard.**  
**Ultraviolet light can cause color shift or structural degradation of plastic HVAC materials.**  
 Select mounting location that prevents exposure to plastic components with *unknown resistance to ultraviolet light*. Three-feet minimum is recommended between ultraviolet lamp and plastic-fabricated devices (such as humidifiers and non-fiberglass media filters).

Depending on installation location, the UV System can operate as an Air Treatment System or as a Surface Treatment System.

### Air Treatment System

Installed in the return air duct, the Air Treatment System kills a high percentage of airborne germs circulating through the forced air heating and cooling system. Individual results depend on careful installation and maintenance and on the actual amount of time the system fan operates. See Fig.1.

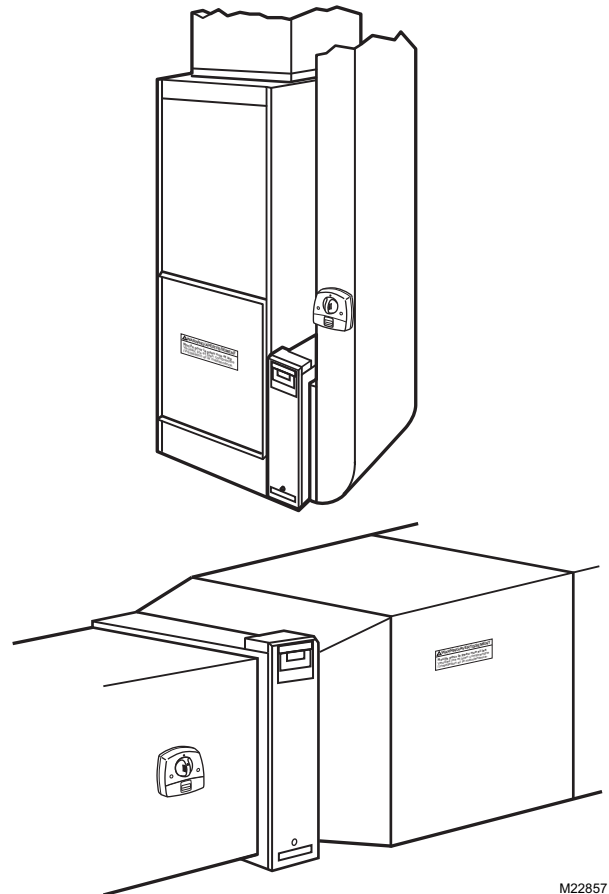

M22857

**Fig. 1. Typical Air Treatment System installations.**

## Surface Treatment System

When installed next to the cooling coil, the Surface Treatment System prevents a high percentage of the growth of micro-organisms such as mold that may grow on duct surfaces, coils and drain pans. Individual results depend on careful installation and maintenance. See Fig. 2.

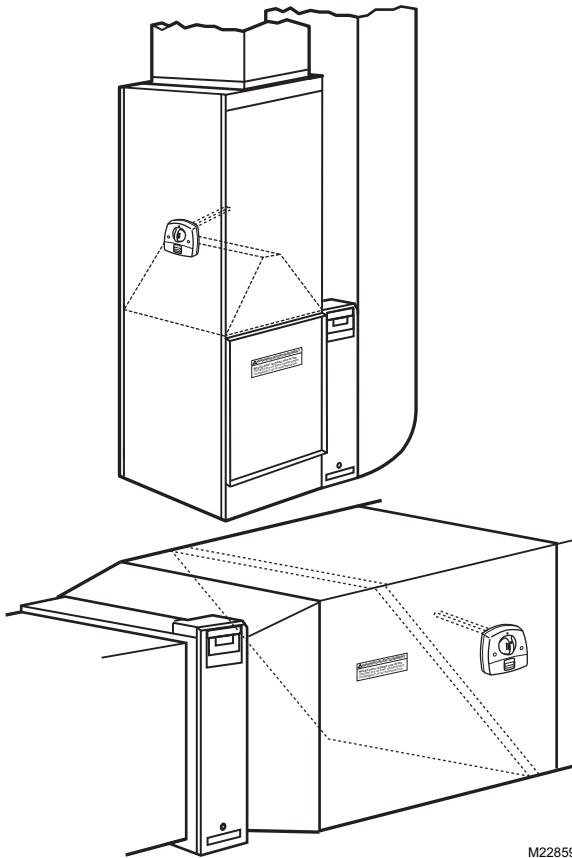

Fig. 2. Typical Surface Treatment installations.

### IMPORTANT

*If mounting options are limited, protect plastic or rubber materials listed in CAUTION with ultraviolet-resistant material such as aluminum foil duct tape.*

NOTE: When the installer is uncertain about whether the drip pan in the installation can tolerate UV exposure, consult the UV exposure white paper, form no. 50-8788, at [hbctechlit.honeywell.com](http://hbctechlit.honeywell.com) Web site.

1. Choose a location that is readily accessible for regular inspection and cleaning. Fig. 1 and 2 and show possible mounting locations.
2. Allow clearance in front of the device for removing the lamp assemblies. Fig. 3 shows lamp assembly lengths.
3. Be sure depth can accommodate full length of UV lamp for your model as shown in Fig. 3.
4. Be sure duct mounting location is 8 in. wide minimum.
5. Be sure 120 Vac electrical outlet is within range of unit to plug in the power cord.
6. Select single-lamp and dual-lamp air treatment system location on HVAC return air duct that is easily accessible with a flat mounting surface. Select surface treatment system location on HVAC supply air duct that is easily accessible with a flat mounting surface; locate the unit so the lamp can surround the evaporator coil and drip pan with ultraviolet light.
7. Mount to allow correct operation:
  - a. Do not mount upside down.
  - b. Do not mount with lamps facing up.



## CAUTION

**Sharp Edges Hazard.**

**Can cause personal injury.**

Be careful when inserting ultraviolet device into sheet metal cutout.

Wear protective gloves when working near sheet metal.

## Duct Mounting

Use the following instructions to mount the UV System on the air duct of an HVAC system:

1. Disconnect power to the HVAC system before installing the UV System.
2. Select the appropriate template for your model (see Fig. 18-20).
3. Place the appropriate template for your model on the duct surface, centering the bulb hole(s) on the duct.
4. Mark the location on the duct for 2 in. diameter bulb hole(s), unit mounting-screw pilot holes, and when installing a return air model, the 1-1/2 in. airflow sensor hole.
5. Cut 2 in. bulb hole(s) and 1-1/2 in. airflow sensor hole in the duct. Remove any burrs. *Note that the airflow sensor protrudes out of backside of device. Be careful to avoid scratching or damaging the airflow sensor.*
6. Use a 3/32 in. drill for pilot holes for mounting screws.
7. Be sure duct surface is flat after all holes are drilled.
8. Position entire base unit on duct. *Be sure bulb and airflow sensor holes in duct align with unit holes. Be careful to avoid scratching or damaging the airflow sensor.*
9. Install unit into duct using three (or two, depending on model) no.10, 2 in. Phillips head sheet metal mounting screws provided. (A spare screw is provided for three-screw model.)
10. Tighten screws to 12 to 14 in.-lb so space between case and duct is sealed.

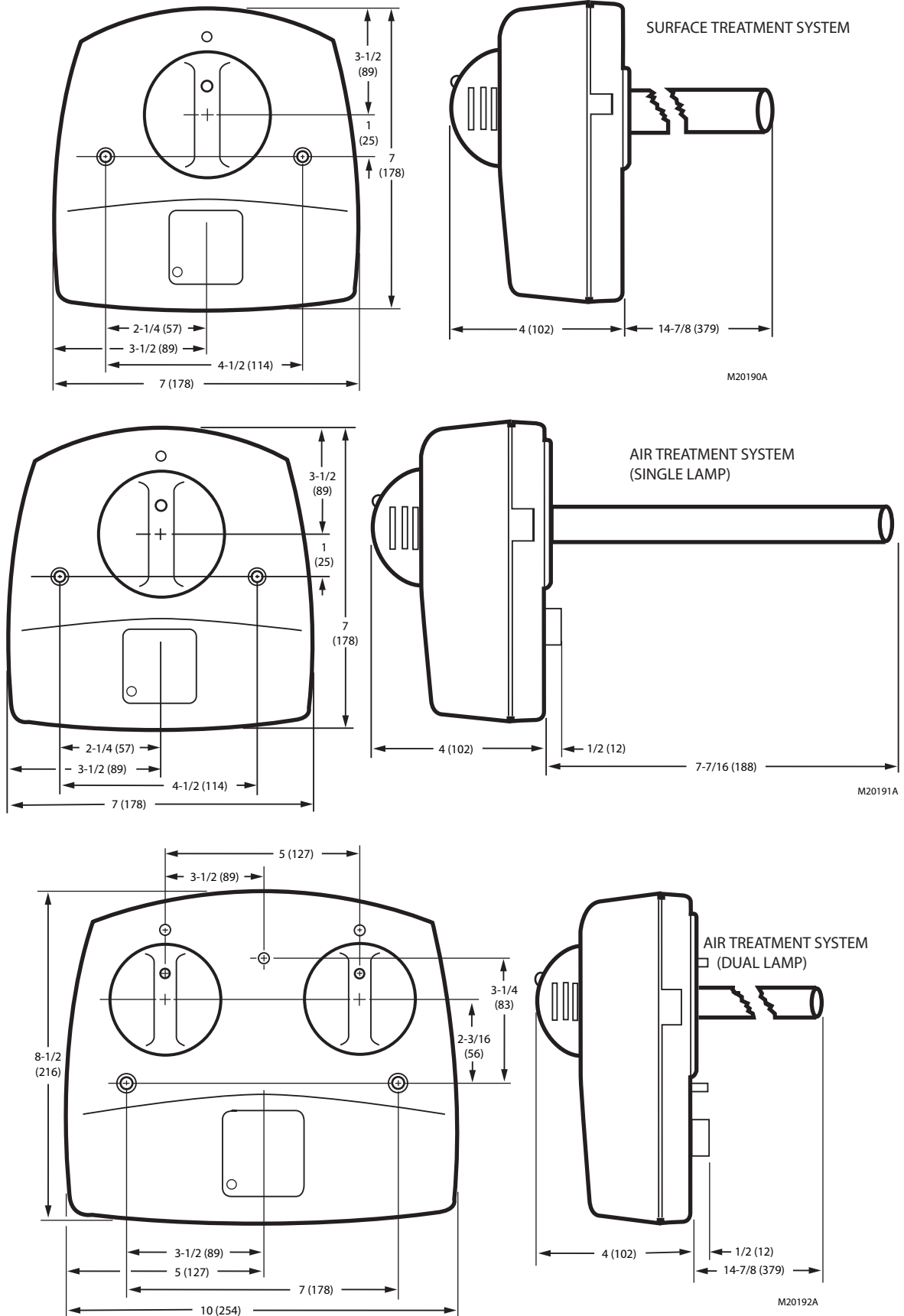

Fig. 3. Ultraviolet System dimensions in in. (mm).

**CAUTION**

**Breakable Glass Hazard.**  
**Can cause personal injury.**  
 Be careful when inserting bulb(s) into lamp base.  
 Wear protective gloves when handling bulb(s).

**MERCURY NOTICE**

This device contains mercury in the sealed ultraviolet bulb(s). Do not place your used bulb(s) in the trash. Dispose of properly.

**Broken Bulb Cleanup.**  
**Do not use a household vacuum.**  
 Sweep debris into a plastic bag and dispose of properly.

Contact your local waste management authority for instructions regarding recycling and the proper disposal of old bulb(s).

11. Insert the lamp handle into the base unit with the lamp light indicator at the eleven o'clock position (left of the raised button on the unit cover). See Fig. 4. If you touch the lamp glass with your hands, use a cloth to wipe fingerprints from the glass. See Fig. 5.

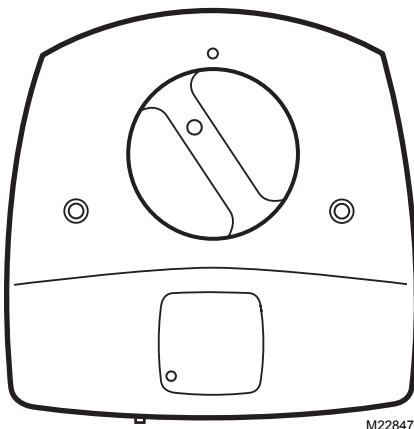

Fig. 4. Insert lamp handle into base unit.

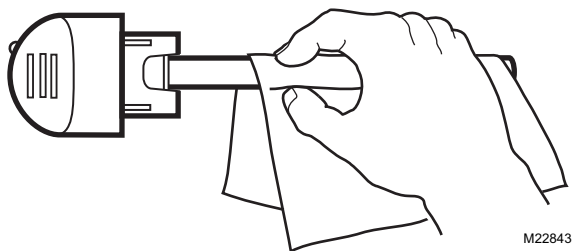

Fig. 5. Use cloth to wipe fingerprints from glass.

12. Continue lightly pushing in on the lamp handle while rotating it slowly counterclockwise. This should cause the lamp handle to drop into the bottom of the lamp well.

13. Rotate the lamp handle clockwise until it snaps into place with the lamp light indicator aligned with the raised button on the unit cover. See Fig. 6.

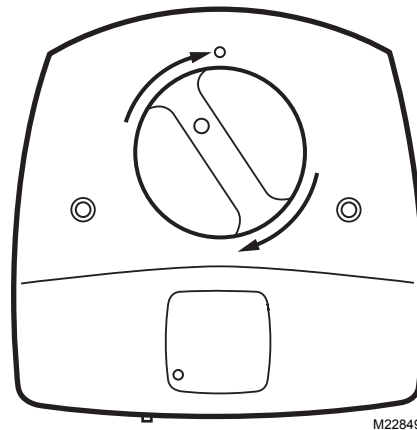

Fig. 6. Snap lamp handle into place.



**WARNING**

**UV Light Hazard.**  
**Harmful to bare skin and eyes.**  
**Can cause temporary or permanent loss of vision.**  
 View illumination only through lamp light indicator located on lamp handle.  
 To prevent exposure to ultraviolet light, disconnect power to ultraviolet system before servicing any part of heating and air conditioning system.

NOTE: If you desire to communicate with other appliances using your Enviracom communication bus, go on to step 14; if not, go directly to step 15.

14. Hook up corresponding appliance wires to the Enviracom communication bus located on the bottom of the UV device base. Be sure to loop wire of other Enviracom appliances or Enviracom common node around the UV base Enviracom screw terminals 1, 2 and 3. See Fig. 7.

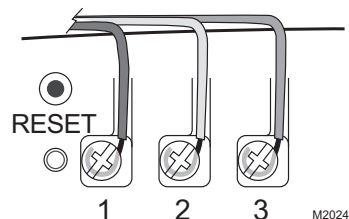

Fig. 7. Looping Enviracom appliance or common node wire around UV Enviracom base screw terminals.

15. Plug the cord into the nearby 120 Vac electrical outlet.

16. For air treatment systems, wait ten minutes for the airflow sensor to calibrate. During this time, the furnace fan must remain off.

NOTE: Failure to wait ten minutes for the airflow sensor to calibrate before powering the furnace causes the airflow sensor to incorrectly calibrate and the device to incorrectly function. If this occurs, remove power to the furnace or turn off the system and fan, wait ten minutes, and then resume normal furnace operation.

17. Reconnect the power to the HVAC system.
18. Choose a location on the adjacent HVAC equipment for the HVAC maintenance UV warning label included in the UV system packing box. Choose a location that a future installer can easily see during any future HVAC maintenance or repair.
19. Adhere the HVAC maintenance UV warning label to the HVAC equipment (selected in step 17) such as the furnace, air cleaner or humidifier. See Fig. 8.

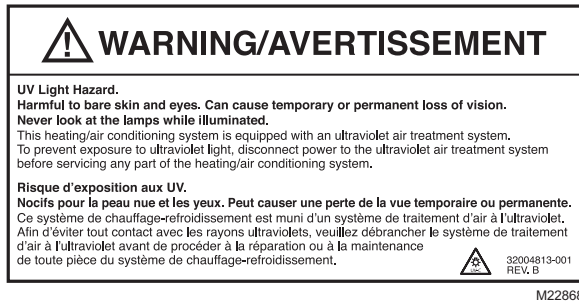

Fig. 8. HVAC maintenance UV safety label.

## CHECKOUT

The installer should verify that the ultraviolet bulb(s) are operating *only by viewing the lamp light indicator on the lamp handle. Do not attempt to look directly into the duct to see the illuminated ultraviolet bulbs.* See Fig. 9.

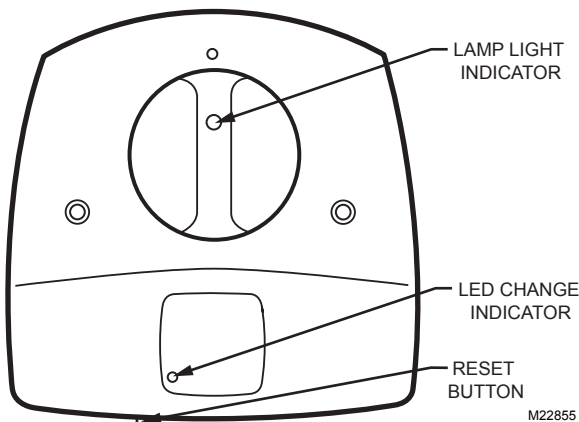

Fig. 9. Lamp light indicator, LED and reset button.

The installer should orient the homeowner to the unit by showing them the blue glow of the lamp light indicator and discussing how to determine when the unit is functioning properly without looking directly into the duct to see the illuminated ultraviolet lamp. The installer should also emphasize the hot surface and electrical shock safety warnings.

The installer should show the homeowner the LED on the front of the UV system and explain operation as follows:

LED Status	Indicates	Homeowner Action
Off	100 to 11% bulb life <sup>a</sup> remaining	Nothing
Flashing	10 to 1% bulb life <sup>a</sup> remaining	Purchases bulb(s)
Solid	0% bulb life <sup>a</sup> remaining	Replaces bulb(s)

<sup>a</sup>Bulb life means emitting adequate amount of UV-C energy to maintain an effective kill rate. At 0% bulb life remaining, the lamp continues to operate until catastrophic bulb failure (bulb burns out) but the kill rate becomes rapidly negligible.

Installer should also orient the homeowner to the reset button on the bottom of the UV system that, when pressed briefly for one second, can be used to command lamp on for the minimum run time of 40 minutes (air treatment system) or three hours (surface treatment system), depending on system type. And that when a new bulb is installed, the homeowner must hold the reset button for five seconds to reset the internal timers. Cycling power does not reset internal timers.

When using Enviracom communication bus to communicate with other appliances, the installer should orient the homeowner to the Enviracom LED and three screw terminals. The Enviracom LED flashes when transmitting and lights solidly when there is a fault.

The installer should also explain the extended-bulb life for the surface treatment system. For the single-lamp and dual-lamp air treatment systems, the installer should orient the homeowner to the alternate method of using the UV system to monitor the thermostat load information to turn lamp off and on instead of using the air flow sensor to control lamp operation and that it communicates the percent remaining bulb life.

The installer should leave the Owner's Guide with the homeowner and review the bulb cleaning and replacement procedures. A Bulb Cleaning Reminder Schedule is included in the Owner's Guide to help the homeowner set up and track a regular cleaning schedule.



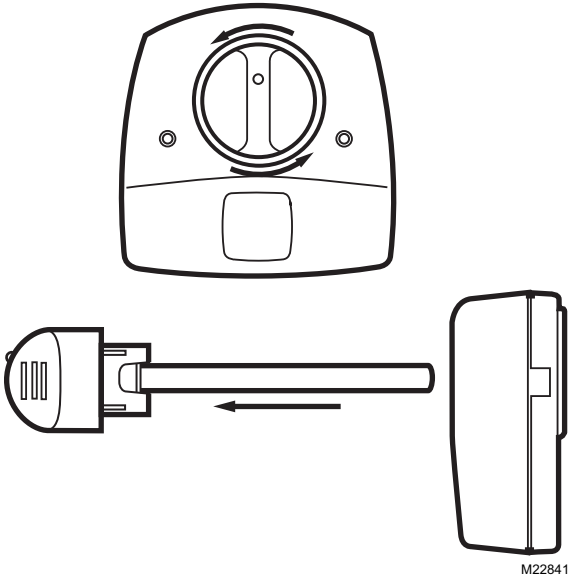

Fig. 11. Remove lamp or bulb.

4. Holding the lamp handle, wipe the lamp glass using a soft cloth dampened with window cleaner. If you touch the lamp glass with your hands, be sure to clean the area of any oils left from bare hands. See Fig. 12.

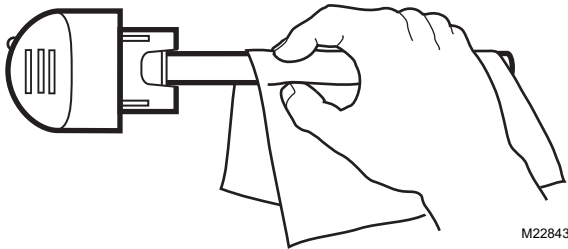

Fig. 12. Clean glass with soft cloth.

5. Also wipe away any dust that may have collected between the lamp light indicator on the base and the black lamp base. See Fig. 13.

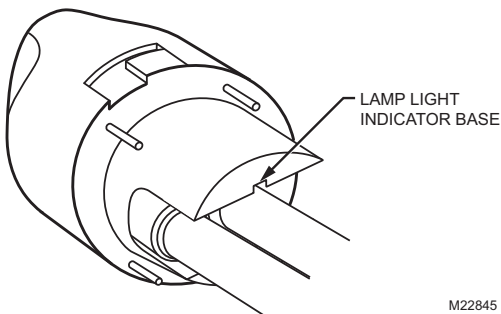

Fig. 13. Wipe lamp light indicator base.

6. Dry bulbs with a clean, dry cloth.

7. Insert the lamp handle into the base with the lamp light indicator at the eleven o'clock position. Continue pushing and gently rotating counterclockwise until the lamp handle inserts fully into the base. See Fig. 14.

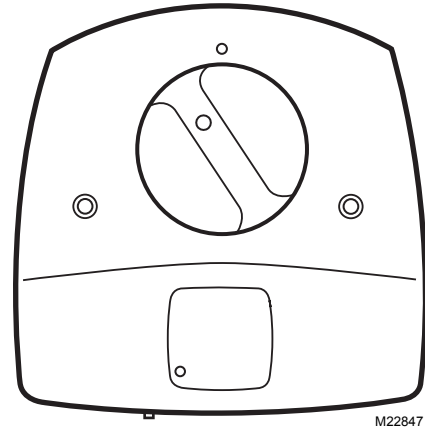

Fig. 14. Position lamp handle for insertion back into lamp base.

8. Rotate the lamp handle clockwise until it snaps into place with the lamp light indicator aligned with the raised button on the unit cover. See Fig. 15.

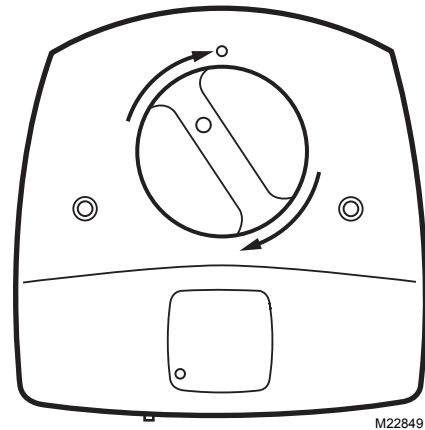

Fig. 15. Snap lamp handle into place.



## WARNING

**UV Light Hazard.**

**Harmful to bare skin and eyes.**

**Can cause temporary or permanent loss of vision.**

Never look at bulbs while illuminated.

View illumination only through lamp light indicator located on lamp handle.

To prevent exposure to ultraviolet light, disconnect power to ultraviolet system before servicing any part of heating and air conditioning system.

9. Reconnect power to your UV System.

- For Air Treatment Systems, wait ten minutes for the airflow sensor to calibrate. During this time, the furnace fan must remain off.

**NOTE:** Failure to wait ten minutes for the airflow sensor to calibrate before powering the system fan causes the airflow sensor to incorrectly calibrate and the device to incorrectly function. If this occurs, remove power to the furnace or turn off the system fan, wait ten minutes, and then resume normal fan operation.

- Verify that ultraviolet lamp is operating by viewing only through the lamp light indicator on the lamp handle. *Never look directly at your bulbs while illuminated.*
- Reconnect power to your heating and cooling system.

### CAUTION

**UV Lamp Burn Hazard.**  
**Harmful to bare skin.**  
**Can cause severe burns.**  
 Disconnect power 15 minutes before removing ultraviolet bulb(s).

### Bulb Replacement

Replacement of the bulb in your ultraviolet lamp when the LED is solidly lighted is required to maintain effectiveness.

- Obtain the correct replacement bulb for your unit. See Table 1.

**Table 1. Select a Replacement Bulb/Handle Assembly or Replacement Bulb.**

Unit Description	Replacement Bulb/Handle Assembly	SnapLamp™ Replacement Bulb
UV100E1043 Air Treatment System	UC100E1006	UC18W1004
UV100E2009 Air Treatment System	UC100E1030 (two required)	UC36W1006 (two required)
UV100E3007 Surface Treatment System	UC100E1030	UC36W1006

- Disconnect power to your heating and cooling system.
- Unplug or turn off power to your UV System and allow the lamp to cool for at least 15 minutes.
- Rotate the lamp handle counterclockwise and gently pull the lamp handle to remove the bulb(s). See Fig. 11.
- If you have a SnapLamp™ handle, follow steps 5 and 6; otherwise, proceed to step 7. Grasp the SnapLamp™ handle in one hand and the lamp glass in the other and pull straight apart. See Fig. 16.

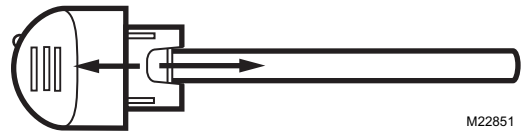

**Fig. 16. Disconnect lamp glass from SnapLamp™ handle.**

- Insert the new lamp glass into the SnapLamp™ handle by aligning the notch and pushing straight together. See Fig. 17.

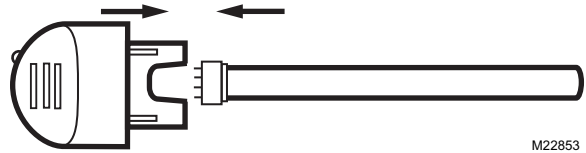

**Fig. 17. Replace lamp glass in SnapLamp™ handle.**

- Insert the lamp handle into the base with the lamp light indicator at the eleven o'clock position. Continue pushing and gently rotating counterclockwise until the lamp handle inserts fully into the base. See Fig. 4.
- Rotate the lamp clockwise until it snaps into place with the lamp light indicator aligned with the raised button on the unit cover. See Fig. 6.
- Reconnect power to your UV System.
- For UV Air Treatment Systems, wait ten minutes for the airflow sensor to calibrate. During this time, the furnace fan must remain off.

**NOTE:** Failure to wait ten minutes for the airflow sensor to calibrate before powering the system fan causes the airflow sensor to incorrectly calibrate and the device to incorrectly function. If this occurs, remove power to the furnace or turn off the system fan, wait ten minutes, and then resume normal fan operation.



### WARNING

**UV Light Hazard.**  
**Harmful to bare skin and eyes.**  
**Can cause temporary or permanent loss of vision.**  
 Never look at bulbs while illuminated.  
 View illumination only through lamp light indicator located on lamp handle.  
 To prevent exposure to ultraviolet light, disconnect power to ultraviolet system before servicing any part of heating and air conditioning system.

- Verify that your ultraviolet lamp is operating by viewing only through the lamp light indicator on the lamp handle. *Never look directly at your bulb while it is illuminated.*
- Reconnect power to your heating and cooling system.
- Press and hold the reset button for five seconds to reset the internal timers.

## PARTS LIST

System Description	Replacement Bulb/Handle Assembly	Replacement Bulb
UV100E1043 Air Treatment System (single-lamp) <b>(left photo)</b>	UC100E1006	UC18W1004
UV100E3007 Surface Treatment System <b>(center photo)</b>	UC100E1030	UC36W1006
UV100E2009 Air Treatment System (dual lamp) <b>(right photo)</b>	UC100E1030 (two required)	UC36W1006 (two required)



## Honeywell

Choose better indoor air for your family by installing Honeywell solutions. You'll enhance your comfort and peace of mind.



### Ultraviolet Systems

**Zap** airborne germs and prevent mold spore growth on air conditioning coils



### Whole-House Air Cleaners

**Trap** a high percentage of airborne particles of the air passing through it



### Whole-House Humidifiers

**Moisturize** air—humidity is ideal for minimizing adverse health effects



### Zoning Systems

**Control** temperature by area in your home, saving energy and improving comfort



### PerfectWindow® Air Exchangers

**Ventilate** your home to assure fresh air while minimizing energy loss



### Programmable Thermostats

**Save** up to 30% in annual energy costs with this easy-to-use thermostat\*

\*depending on geography and usage

M18621B

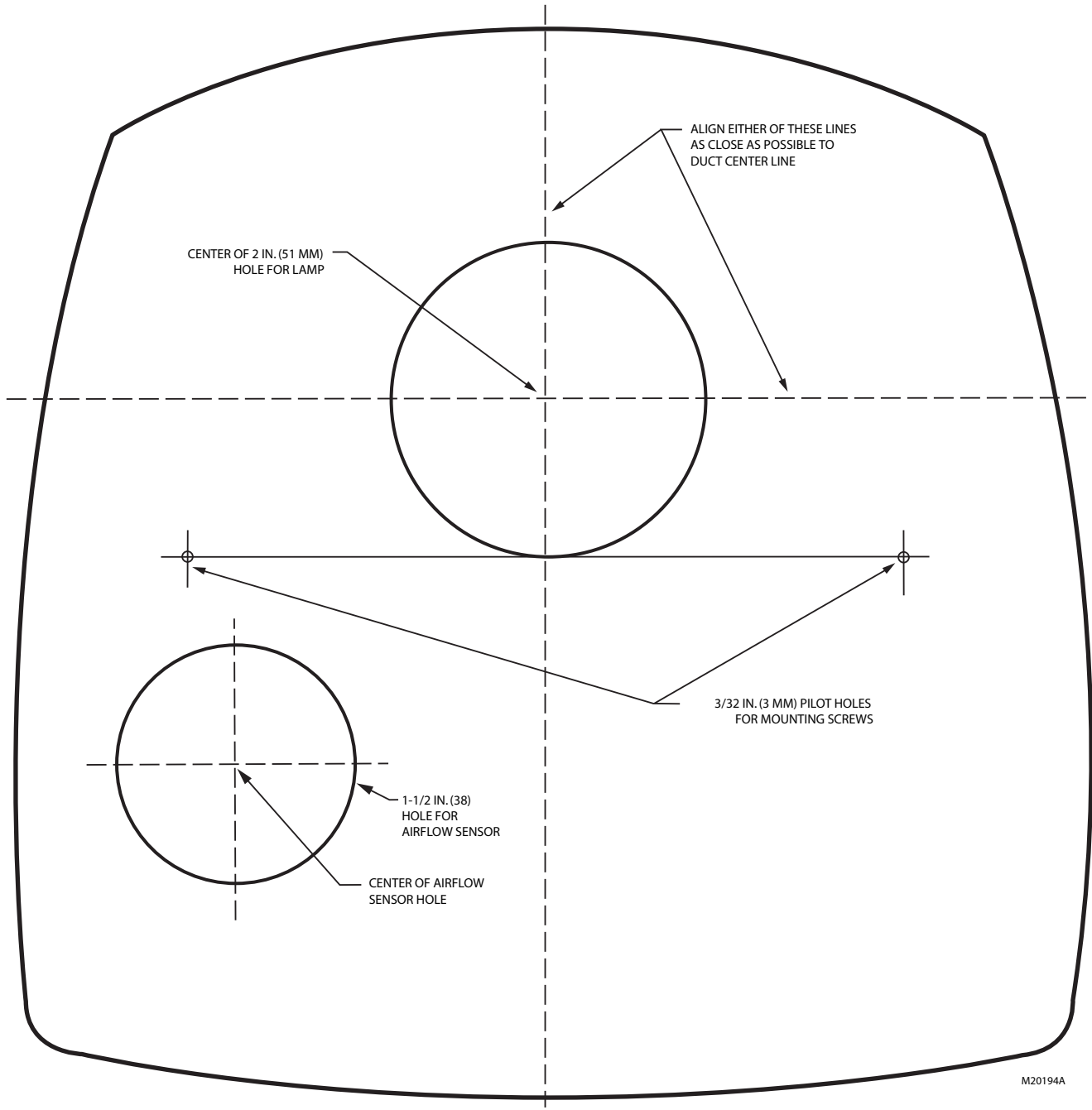

INSTALLATION TEMPLATE FOR AIR TREATMENT SYSTEM (SINGLE-LAMP).

**Fig. 18. Air Treatment System (single lamp) template.**

(Air Treatment System (dual lamp) template is located on next page.)

**Fig. 19. Air Treatment System (dual lamp) template.**

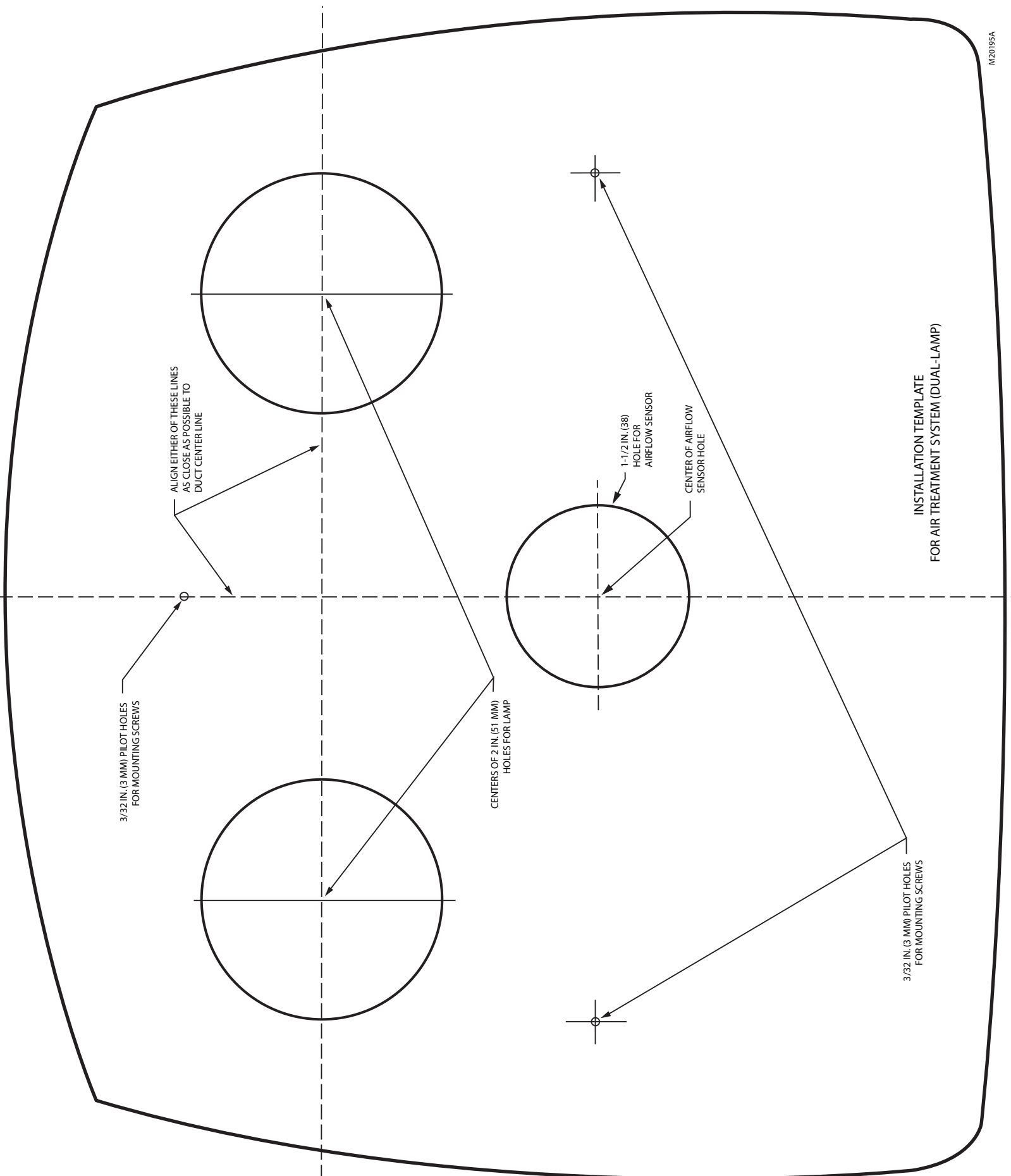

3/32 IN. (3 MM) PILOT HOLES FOR MOUNTING SCREWS

ALIGN EITHER OF THESE LINES AS CLOSE AS POSSIBLE TO DUCT CENTER LINE

CENTERS OF 2 IN. (51 MM) HOLES FOR LAMP

1-1/2 IN. (38) HOLE FOR AIRFLOW SENSOR

CENTER OF AIRFLOW SENSOR HOLE

3/32 IN. (3 MM) PILOT HOLES FOR MOUNTING SCREWS

INSTALLATION TEMPLATE FOR AIR TREATMENT SYSTEM (DUAL-LAMP)

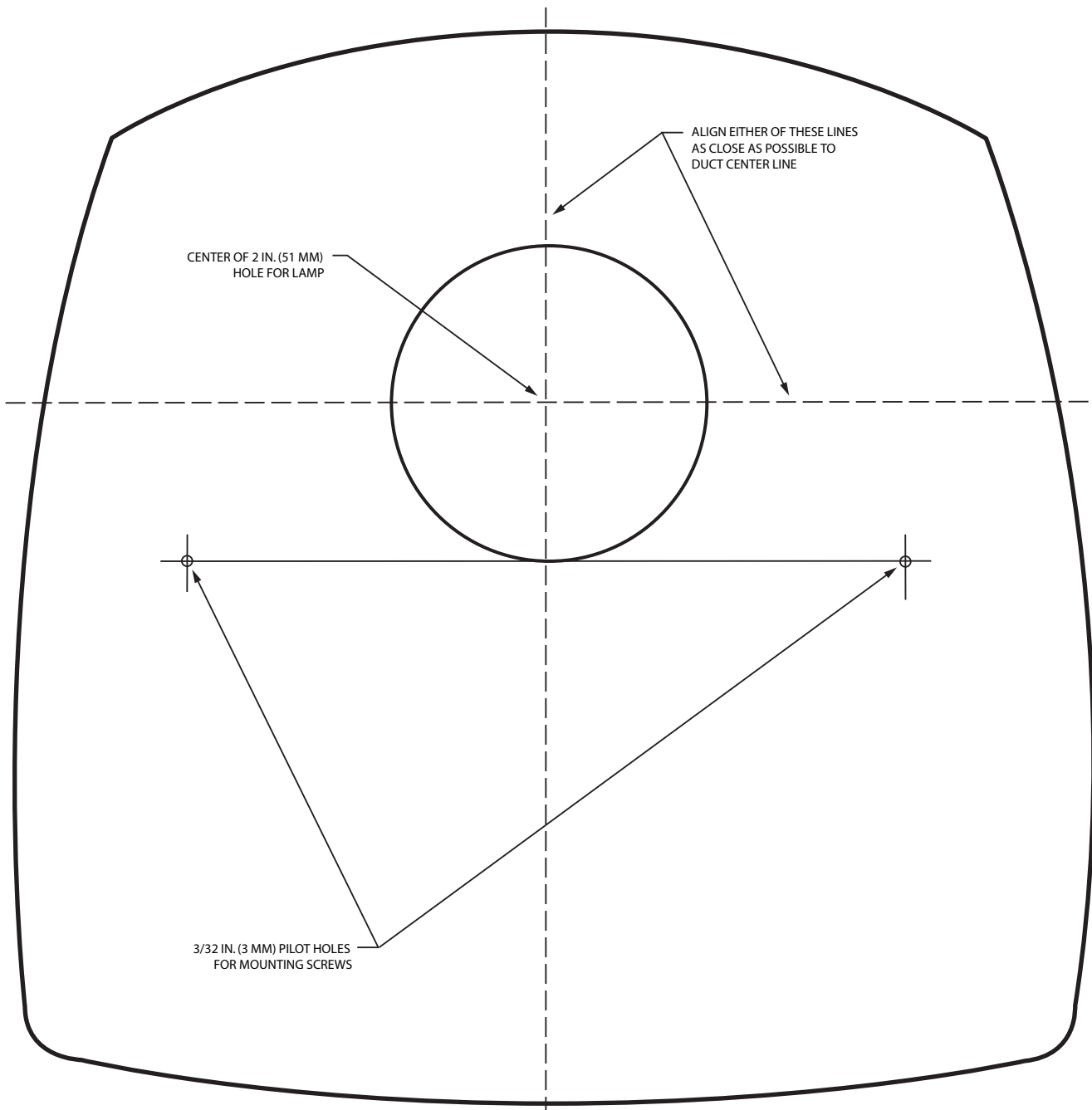

INSTALLATION TEMPLATE FOR SURFACE TREATMENT SYSTEM

M20193A

**Fig. 20. Surface Treatment System template.**



**Automation and Control Solutions**

Honeywell International Inc.  
1985 Douglas Drive North  
Golden Valley, MN 55422  
customer.honeywell.com

Honeywell Limited-Honeywell Limitée  
35 Dynamic Drive  
Toronto, Ontario M1V 4Z9

® U.S. Registered Trademark  
© 2007 Honeywell International Inc.  
68-0262—5 M.S. Rev. 03-07



Printed in U.S.A. on recycled  
paper containing at least 10%  
post-consumer paper fibers.

**Honeywell**