

V5011N Two-Way Threaded Globe Valve



The V5011N is a two-way threaded globe valve for control of steam, water, and glycol solutions (up to 50 percent concentration) in heating or cooling HVAC applications. These valves are used in two-position and modulating control systems. The valve is not suitable for combustible gas service.

SPECIFICATIONS

Models:

- V5011N Valves: Two-way threaded globe valves for steam, water, or glycol. NPT-threaded pipe connections. Throttling plug provides equal percentage flow characteristic for water (V5011N1xxx, V5011N3xxx), linear flow characteristic for steam (V5011N2xxx). Push down valve stem to close.

Valve Sizes and Flow Capacities:

Size (in.)	Capacity (C _v)
1/2	0.73
	1.16
	1.85
	2.9
	4.7
3/4	7.3
1	11.7
1-1/4	18.7
1-1/2	29.3
2	46.8

Pipe Connections:

- Female NPT-threaded connections.

Seat:

- Stainless steel, replaceable (except V5011N3xxx 3/4 in. to 1-1/4 in. which have internal brass seat).

ANSI Body Class:

- 150 psi.

Stem:

- Stainless steel.

Plug:

- Brass on models for water (V5011N1xxx and V5011N3xxx) stainless steel on models for steam (V5011N2xxx).

Stroke:

- 3/4 in. (20 mm).

Approximate Leakage Rate:

- 0.05 percent of C_v.

Pattern:

- 2-way, straight-through.

SPECIFICATION DATA

FEATURES

- Red brass body with NPT-threaded end connections.
- Low seat leakage rate (≤ 0.05 percent of C_v).
- Spring-loaded, self-adjusting packing.
- 50:1 rangeability per VDI/VDE 2173.
- Accurate positioning to ensure state-of-the-art temperature control.
- Directly coupled electric and pneumatic actuators for easy mounting.
- Sizes range from 1/2 in. to 2 in.
- Valve designs provide equal percentage flow characteristic for water and linear flow characteristic for steam.
- Repack and rebuild kits for field servicing.

Body Material:

- Red brass.

Packing:

- Spring-loaded, carbon fiber reinforced V-rings.

Pressure-Temperature Body Ratings:

- Water:
 - 36°F to 248°F, 217 psi (15 bar).
 - 248°F to 340°F, 185 psi (12.8 bar).
 - Maximum water differential pressure: 230 psid (15.8 bar).
- Steam:
 - 100 psi (6.9 bar) at 337°F (V5011N2xxx).

Valve Flow Characteristics:

- Water: equal percentage flow characteristic (V5011N1xxx, V5011N3xxx).
- Steam: linear flow characteristic (V5011N2xxx).

Close-Off Pressure Ratings:

- Refer to the product data, 63-2548.

Maximum Pressure Differential for Quiet Water Service:

- 20 psi differential.

Rangeability:

- 50:1 per VDI/VDE 2173

Motor and Linkage Selection:

Electric	Pneumatic
ML6421/ML6425	MP953C (5 and 8 in.)
ML7421/ML7425	MP953E (5 and 8 in.)
ML7984/ML6984	—
Modutrol IV with Q5001	—
Damper DCA with Q5020	—



Dimensions:

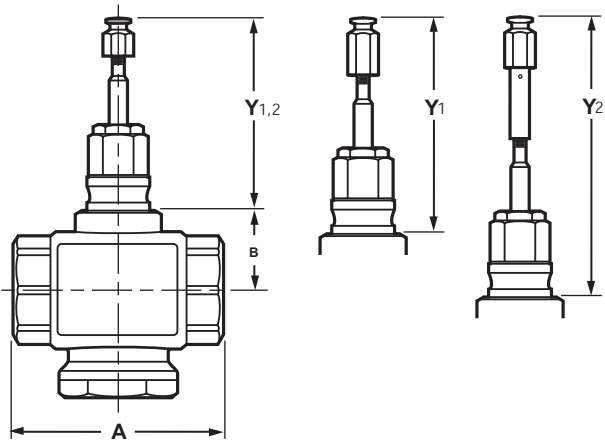

VALVE SIZE (IN)	A in. (mm)	B in. (mm)
1/2	3-1/4 (83)	1-9/16 (40)
3/4		
1	4-1/16 (103)	
1-1/4	4-3/16 (106)	
1-1/2	4-3/4 (120)	1-13/16 (47)
2	5-1/4 (134)	

VALVE	Y1 in. (mm)	Y2 ^a in. (mm)
V5011N1XXX	3-1/2 (89)	5-1/4 (133)
OR		
V5011N2XXX	STEM FULLY DOWN	
V5011N3XXX	4-3/16 (107)	5-15/16 (151)
	STEM FULLY UP	

^aY2 WITH STEM EXTENSION FOR MP953C,E (8 IN. ONLY)

M17378A

TYPICAL SPECIFICATIONS

Automatic control valves shall have threaded type fittings, 1/2 in. through 2 in. sizes, and shall be ANSI-rated to withstand the pressures and temperatures encountered.

Valves shall have metal-to-metal seats, stainless-steel stems, and replaceable spring-loaded reinforced carbon filled teflon packing.

Valves shall have a leakage rate of 0.05% C_V or less. Valves shall have a 50:1 rangeability or better.

All two way water valves shall be provided with equal-percentage contoured throttling plugs. All steam valves shall be provided with linear contoured throttling plugs.

ACCESSORIES

Stem Button:

- 090116

Repack Kits:

- 0901786 for 1/4 in. stems (1/2 in. through 1-1/4 in. valves).
- 0901787 for 3/8 in. stems (1-1/2 in. through 2" valves).

Rebuild Kits:

- Refer to V5011N Two-Way Threaded Globe Valve Product Data, form 63-2548.



V5013N Three-Way Threaded Globe Valve

PRODUCT DATA

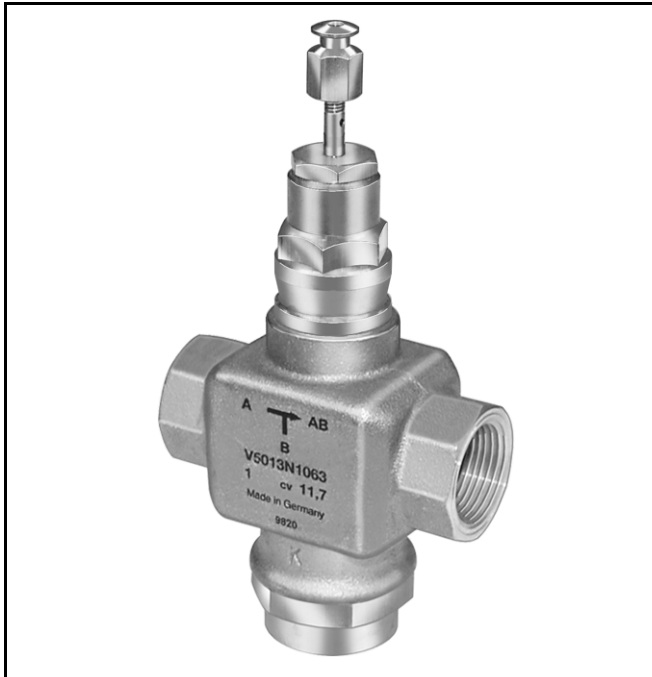

FEATURES

- Red brass body with NPT-threaded connections.
- Stainless steel stem and brass plug.
- Low seat leakage rate (≤ 0.05 percent of C_v).
- Spring-loaded, self-adjusting packing.
- 50:1 rangeability per VDI/VDE 2173.
- Constant total flow throughout full stem travel.
- Accurate positioning to ensure state of the art temperature control.
- Sizes range from 1/2 in. to 2 in.
- Suitable for pneumatic or electric/electronic actuation.
- Repack and rebuild kits available for field servicing.

APPLICATION

The V5013N is a three-way threaded globe valve that controls hot water, cold water, and glycol solutions (up to 50 percent concentration) in heating or cooling HVAC applications. The valve is used for mixing service to direct flow from one of two inlets to a common outlet in two-position or modulating control systems.



SPECIFICATIONS

IMPORTANT

The specifications given in this publication do not include normal manufacturing tolerances. Therefore, an individual unit may not exactly match the listed specifications. Also, this product is tested and calibrated under closely controlled conditions and some minor differences in performance can be expected if those conditions are changed.

Models:

V5013N Valve: Three-way mixing valve for water or glycol. NPT-threaded pipe connections. Constant total flow. Push down valve stem to close bottom (B) port.

Dimensions: See Fig. 1.

Valve Sizes and Flow Capacities: See Table 1.

Pipe Connections: Internally-threaded NPT connections.

Seat:

1/2 in.: Replaceable stainless steel (upper), replaceable brass (lower).
3/4 in. to 2 in.: Integral brass (upper), replaceable brass (lower).

ANSI Body Class: 150 psi.

Stem: Stainless steel.

Plug: Brass.

Stroke: 3/4 in. (20 mm).

Approximate Leakage Rate: 0.05 percent C_v .

Rangeability: 50:1 per VDI/DE 2173.

Body Material: Red brass.

Packing: Spring-loaded, carbon fiber reinforced PTFE V-rings.

Close-Off Pressure Ratings: See Fig. 2 and Table 2.

Pressure-Temperature Ratings:

Water: 36°F to 248°F, 217 psi (15 bar).
248°F to 337°F, 185 psi (12.8 bar).
Maximum Water Differential Pressure: 230 psid (15.8 bar).

Maximum Differential for Quiet Water Service: 20 psid.

Valve Flow Characteristics:

Port A-AB: Equal percentage.
Port B-AB: Linear.

NOTE: Movement of the valve stem at any point of the flow range does not significantly change the total flow rate at the AB outlet port (constant total flow).

Valve Design Life: 250,000 full cycles at maximum rated temperature.

Replacement Parts: See Fig. 3 and Table 3.

Motor and Linkage Selection:

Electric	Pneumatic
ML6421/ML6425	MP953C (5 and 8 in.)
ML7421/ML7425	MP953E (5 and 8 in.)
ML7984/ML6984	—
Modutrol IV with Q5001	—
Damper DCA with Q5020	—

Table 1. Valve Size and Flow Capacities.

Size (in.)	Capacity (C_v)
1/2	2.9
	4.7
3/4	7.3
1	11.7
1-1/4	18.7
1-1/2	29.3
2	46.8

ORDERING INFORMATION

When purchasing replacement and modernization products from your TRADELINE® wholesaler or distributor, refer to the TRADELINE® Catalog or price sheets for complete ordering number.

If you have additional questions, need further information, or would like to comment on our products or services, please write or phone:

1. Your local Honeywell Automation and Control Products Sales Office (check white pages of your phone directory).
2. Honeywell Customer Care
1885 Douglas Drive North
Minneapolis, Minnesota 55422-4386

In Canada—Honeywell Limited/Honeywell Limitée, 35 Dynamic Drive, Scarborough, Ontario M1V 4Z9.

International Sales and Service Offices in all principal cities of the world. Manufacturing in Australia, Canada, Finland, France, Germany, Japan, Mexico, Netherlands, Spain, Taiwan, United Kingdom, U.S.A.

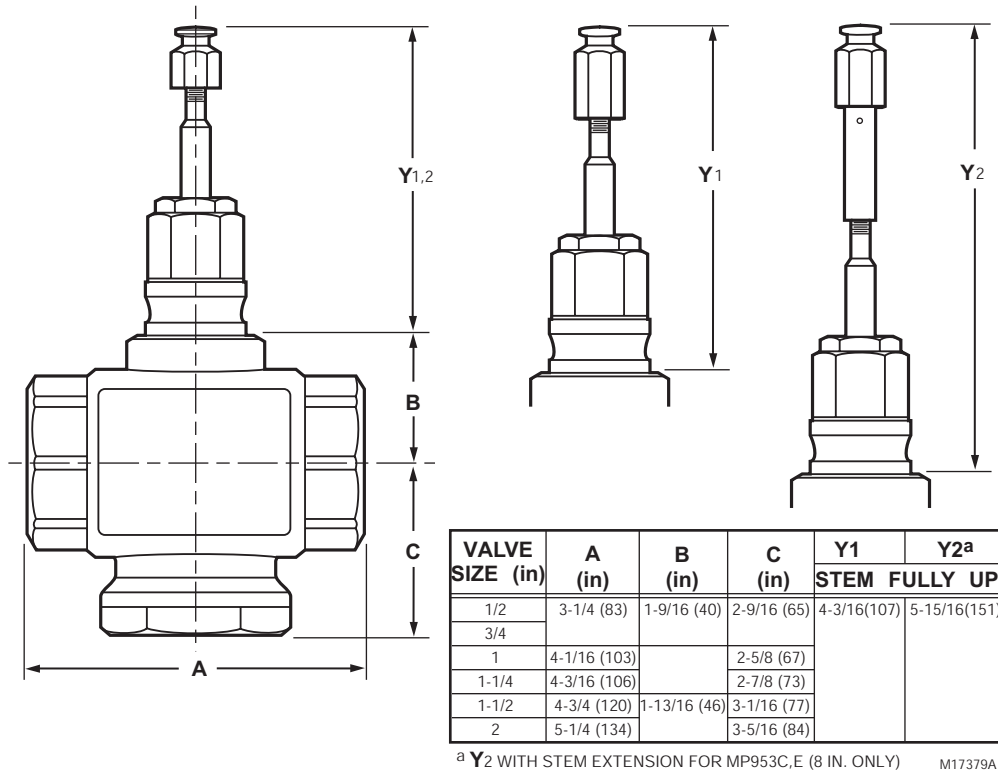
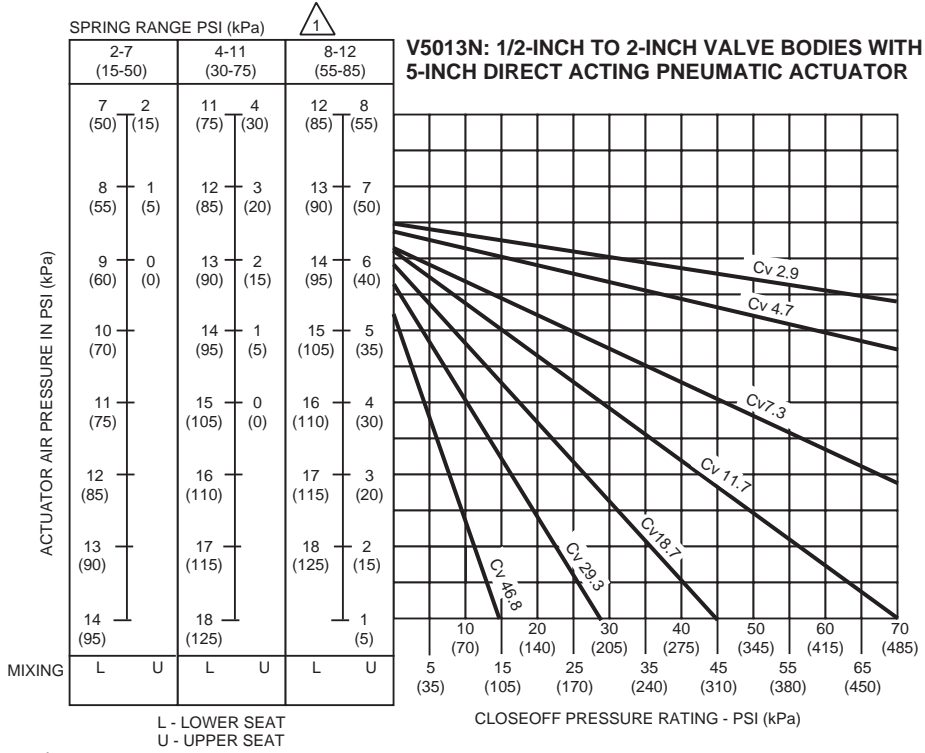

Fig. 1. V5013N body dimensions in in. (mm).

Table 2. Close-off Ratings (psid) for V5013N Valves with Electric/Electronic Actuators and Q5001 Linkages.

Valve Size (NPT)	Mod IV Motor with Q5001 Linkages			ML6421A, ML7421A	ML6425, ML7425 ML6420, ML7420	ML7984, ML6874
	320 lb	160 lb	80 lb	405 lb	135 lb	160 lb
1/2 in. (C _v = 2.9)	—	230 ^a	230 ^a	—	230 ^a	230 ^a
1/2 in. (C _v = 4.7)	—	230 ^a	230 ^a	—	230 ^a	230 ^a
3/4	—	230 ^a	131	—	230 ^a	230 ^a
1	230 ^a	196	91	230 ^a	163	196
1-1/4	230 ^a	126	57	230 ^a	104	126
1-1/2	173	81	36	221	67	81
2	98	46	19	126	37	46

^a Pressure limited by fluid temperature; see valve temperature/pressure ratings.



1 USE 4-11 PSI (30-75 kPa) RANGE FOR DETERMINING CLOSEOFF OF VALVES WITH MP953E ACTUATORS.

M12909

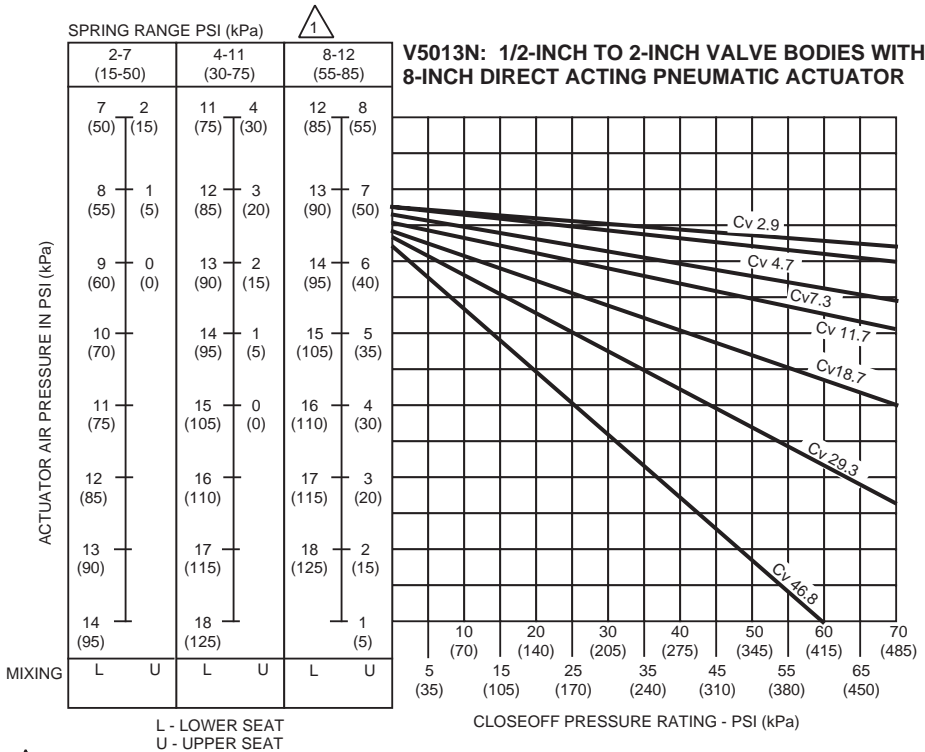

1 USE 4-11 PSI (30-75 kPa) RANGE FOR DETERMINING CLOSEOFF OF VALVES WITH MP953E ACTUATORS.

M12908

Fig. 2. Close-off ratings at various control air pressures for V5013N Valves and MP953 Pneumatic Actuators.

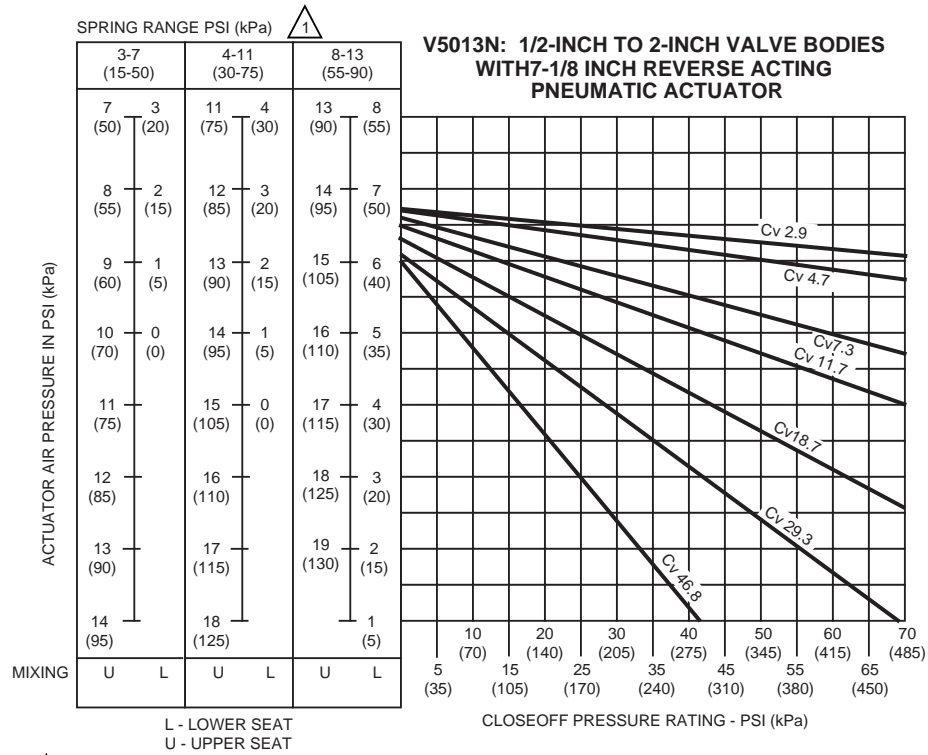

M12907

Fig. 2. Close-off ratings at various control air pressures for V5013N Valves and MP953 Pneumatic Actuators. (continued)

Table 3. V5013N Replacement Parts.

Valve OS No.	NPT Size (in.)	Flow Capacity (C _v)	Stem Diameter (in.)	Repack Kit (Part No.)	Rebuild Kit (Part No.)	Stem Button (Part No.)
V5013N1030	1/2	2.9	1/4	0901786A	0901759A	0901116A ^a
V5013N1048		4.7			0901760A	
V5013N1055	3/4	7.3			0901761A	
V5013N1063	1	11.7			0901762A	
V5013N1071	1-1/4	18.7			0901763A	
V5013N1089	1-1/2	29.3			3/8	
V5013N1097	2	46.8	0901765A			

^aEach 0901116A contains 10 stem buttons.

NOTE: 32003941-001 Seat Removal Tool required to rebuild 1/2 in. valves. Other sizes do not require this tool.

V5013N THREE-WAY GLOBE VALVES

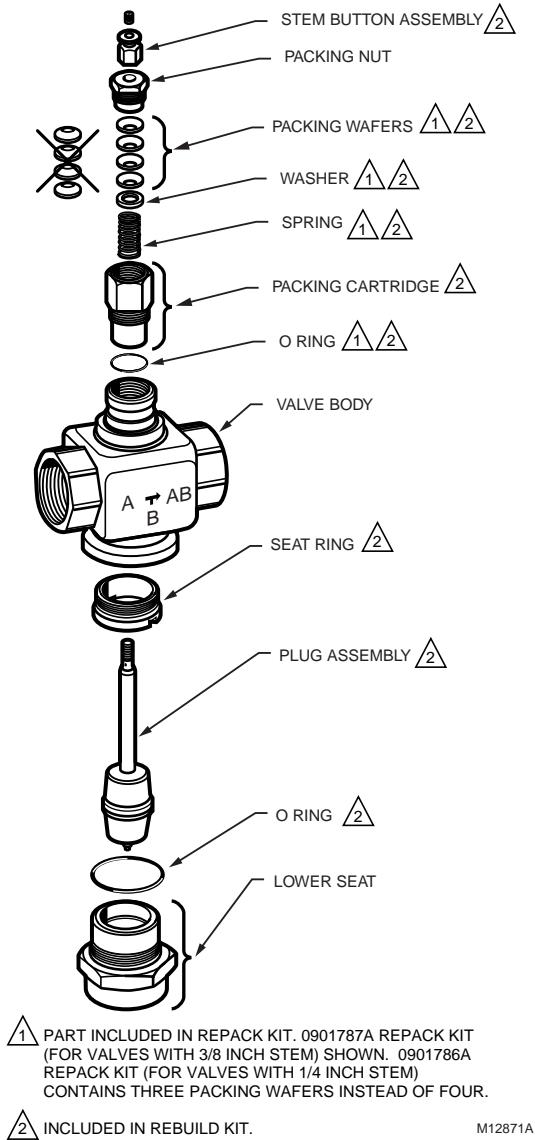

Fig. 3. V5013N replacement parts.

INSTALLATION

When Installing this Product...

1. Read these instructions carefully. Failure to follow them could damage the product or cause a hazardous condition.
2. Check the ratings given in the instructions and on the product to make sure the product is suitable for your application.
3. Installer must be a trained, experienced service technician.
4. After installation is complete, check out product operation as provided in these instructions.

IMPORTANT

1. Do not lift the valve by holding the stem.
2. Do not mount the valve with the stem pointed lower than horizontal.
3. Mount the valve with the flow arrow pointed in the direction of flow through the valve.
4. Mount the valve between aligned pipes. Mounting the valve on pipes that are not aligned causes leakage at the valve to pipe connection.
5. Ensure complete engagement on pipe to valve body threads.
6. Hold the valve body with a clamp or pipe wrench on the hexagonal fitting nearest the pipe to prevent damage to the valve body while mounting on the pipe. Refer to Fig. 7.
7. Be sure to allow enough room for installation and service. Clearance for valve installation is dependent on the actuator size and valve pipe size.

Location

Select a location where the valve, linkage (if used), and actuator to be used are within the appropriate ambient pressure and temperature ratings.

Leave sufficient clearance above the valve to accommodate actuator installation and room for servicing the valve body. (Completely install the valve body in the pipe line before installing the actuator and linkage.)

When selecting a location for the valve, consider actuator mounting restrictions. Modutrol IV™ Motors require crankshafts to be mounted horizontally.

Mounting

The preferred mounting position of the valve is with the stem vertical. Do not mount the valve with the stem more than 90 degrees from the vertical (pointing lower than horizontal). Scale and foreign material can collect and can score the stem and cause packing leakage. Protect the stem from damage due to bending or scratching.

Piping Hookups

All piping must comply with local codes and ordinances. Refer to Fig. 4 through 6 for typical piping hookups.

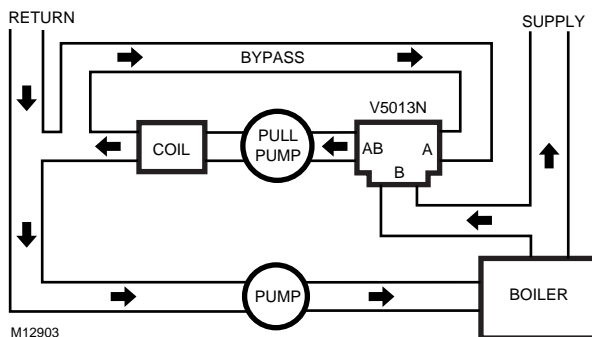

Fig. 4. Typical V5013N mixing valve with constant volume through coil.

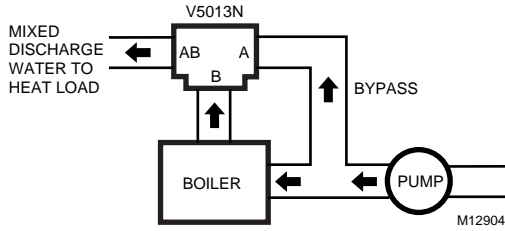

Fig. 5. Single zone bypass for reset control.

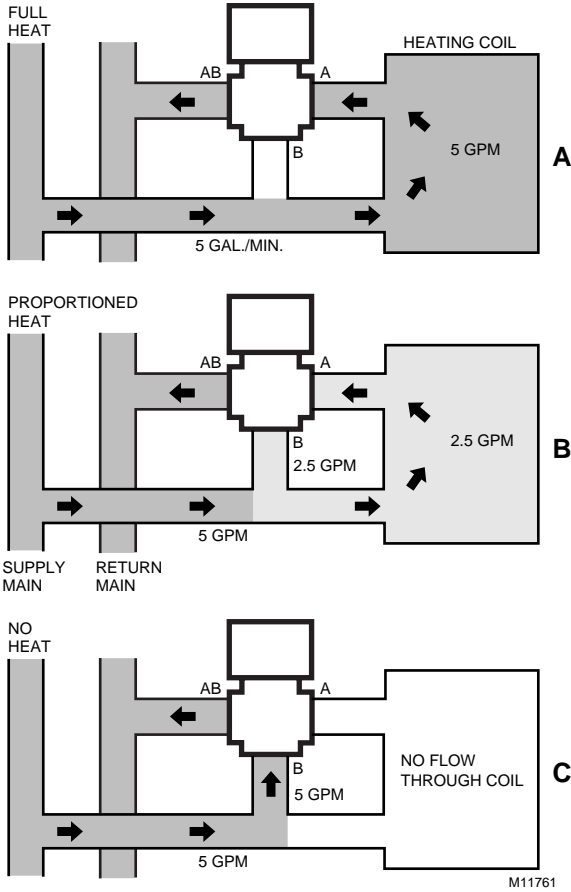

Fig. 6. Three-way mixing valve operation with coil bypass.

NOTE: Three-way valves maintain constant flow in piping. As temperature requirements change, volume of fluid varies in the coil.

Threaded Valve Bodies

Threading on threaded bodies conform to NPT.

IMPORTANT

1. Before installing linkage and actuator, make sure that the valve stem operates freely. Impaired stem operation can indicate that the body was twisted or the stem was bent. Either of these conditions can require valve replacement.
2. Align the pipes squarely with the valve at each end connection.
3. If the pipes are forced into the valve, the body can become twisted and improper seating can result.
4. Apply pipe dope sparingly.
5. Be careful to prevent pipe debris, such as chips and scale, from entering the piping because this material can lodge in the seat and prevent proper closing.

NOTES:

- Threading on threaded bodies conform to NPT.
- Installing a strainer is strongly recommended.

Refer to Fig. 7 for valve pipe sizes and thread lengths. Fig. 7 also shows two effective methods of holding the valve and pipe when attaching it. The valve will not function properly if twisted or squeezed during installation.

Refer to installation information furnished with the linkage and motor when installing these controls.

PIPE SIZE (IN.)	EFFECTIVE LENGTH OF THREADS IN IN. (MM)
1/2	1/2 (12.7)
3/4	9/16 (14.3)
1	11/16 (17.5)
1-1/4	11/16 (17.5)
1-1/2	11/16 (17.5)
2	3/4 (19.1)

- 1 USE PROPERLY REAMED AND CLEANED PIPE AND MODERATE AMOUNT OF DOPE (LEAVE TWO THREADS BARE).
- 2 USE VISE GRIPS WITH THE HEX END NEXT TO THE PIPE (DO NOT TWIST OR SQUEEZE VALVE BODY).
- 3 USE VISE TO HOLD PIPE SECURELY TO PREVENT TURNING. USE PARALLEL-JAW WRENCH TO GRIP VALVE HEX FLATS NEXT TO PIPE.

Fig. 7. Installing valves with threaded connections.

CHECKOUT

Use the following procedure to check for proper valve operation:

1. Check the valve body and connections for leaks.

IMPORTANT

Before installing linkage and actuator, make sure that the valve stem operates freely. Impaired stem operation can indicate that the body was twisted or the stem was bent. Either of these conditions can require valve replacement.

2. After installing linkage and actuator, check the operation according to the installation information furnished with these controls.

3. Operate the system through one complete cycle to ensure the valve controls properly.
4. Check the valve at regular intervals for leakage around the packing.

NOTE: The packing is spring-loaded and should seldom require attention.

5. If leakage is discovered and inspection shows that the packing gland is screwed down tightly, then repack the valve.

Honeywell

Automation and Control Solutions

Honeywell International Inc. Honeywell Limited-Honeywell Limitée
1985 Douglas Drive North 35 Dynamic Drive
Golden Valley, MN 55422 Scarborough, Ontario
M1V 4Z9

Honeywell International

Control Products
Honeywell Building
17 Changi Business Park Central 1
Singapore 486073

Honeywell Europe S.A.

3 Avenue du Bourget
1140 Brussels
Belgium

Honeywell Latin American Region

480 Sawgrass Corporate Parkway
Suite 200
Sunrise FL 33325

