

VBN2, VBN3 Control Ball Valves With Threaded Connections

SPECIFICATION DATA

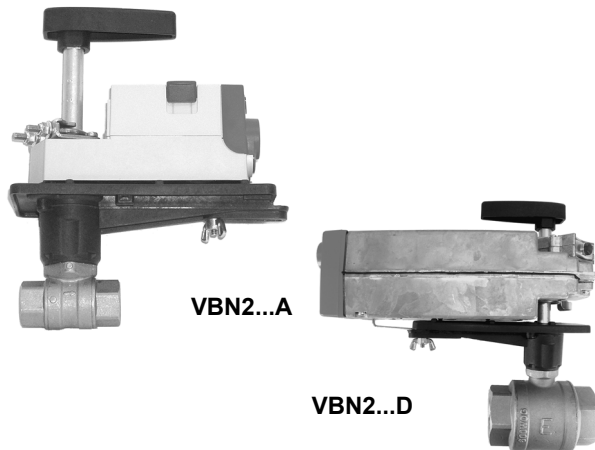

VBN2...A

VBN2...D

APPLICATION

The VBN2 Two-Way and the VBN3 Three-Way Control Ball Valves control hot and chilled water with glycol solutions up to 50% in heating, ventilating, and air conditioning (HVAC) systems to provide two-position or modulating functions.

These valve assemblies can be ordered with or without factory-mounted non-spring return or spring return direct-coupled actuators (DCA).

FEATURES

All Models

- Sizes from 1/2 to 2-1/2 inches with internal (female) NPT connections.
- Straight-through flow between A and AB ports.
- Equal percentage or linear flow characteristics.
- Choice of four, factory-installed actuation control schemes: Floating, Modulating (2-10 V), Spring Return 2-Position, Spring Return Modulating/Floating.
- Field configurable for normally open or normally closed fail-safe position.
- Removable manual operating handle to control valve during installation or in an event of power failure.
- ANSI Class IV seat leakage specification (0.01% of C_V).
- Optional NEMA 3R (IP54) rated enclosure for outdoor applications.
- Actuator can be mounted on the valve in any of four positions.

VBN2 (Two-way)

- Sizes up to 3 inches.
- Wide C_V choices from 0.38 to 266.
- Nickel-chrome plated brass or 316 stainless steel valve ball and stem.

VBN3 (Three-way)

- Wide C_V choices from 0.33 to 109.
- Valve installs in a globe valve "T" pattern, no extra elbows or piping required.
- Nickel-chrome plated brass valve ball and stem.
- Mixing or Diverting control.
- Convertible to straight-through 2-way control by plugging B port (plug not provided.)



SPECIFICATIONS

Table 1. Model Selection.

Valve	Fitting	Body/ Flow Type	Size	C _v	T/P	Trim	Enclosure	Actuator	
VB = valve, ball									
N = Female NPT threaded									
2 = 2 way equal percentage, or linear flow characteristic, as noted in Table 1.									
3 = 3 way mixing equal percentage, or linear flow characteristic, as noted in Table 2.									
			inch	S.I. metric					
			A—	1/2	DN15				
			B—	3/4	DN20				
			C—	1	DN25				
			D—	1-1/4	DN32				
			E—	1-1/2	DN40				
			F—	2	DN50				
			G—	2-1/2	DN65				
			H—	3	DN80				
			B						
			C						
			D						
			E						
			F	C _v Designator					
			See Table 1 for Two-way valves.					
			See Table 2 for Three-way valves.					
			T						
			U						
			1						
			2						
			3 = ANSI 300 Valve construction						
			P = Plated (chrome or nickel)						
			S = Stainless Steel						
			0 = no enclosure						
			R = NEMA 3R enclosure						
			X = no actuator						
			A = NSR, Floating						
			B = NSR, Modulating						
			C = SR, 2-Position, 24 Vac						
			D = SR, Floating/Modulating						
VB	N	2	A	B	3	P	0	A	

Dimensions: See Fig. 1 and 2.

Body Style: Two-way ball valve, straight-through flow, full or reduced port using patented flow control insert.
 Three-way ball valve, A-B-AB flow, full or reduced port using patented flow control insert.
 Internal NPT connections.

Body Size:
 1/2 to 3 inches NPT (two-way).
 1/2 to 2-1/2 inches NPT (three-way).

Flow Capacity: See Tables 2 and 3.

Body Pressure Rating (maximum): 360 psi (2482 kPa) at 250°F (121°C).

Controlled Medium: Water or Glycol solutions up to 50%.
 Not suitable for combustible gases.

Medium Temperature Range:
 -22 to +250°F (-30 to +121°C).

Maximum Differential Pressure: See Table 5.

Flow Characteristics:
 Two-way: Equal Percentage with flow control insert.
 Linear with full port.
 Three-way: Port A to AB: Equal Percentage.
 Port B to AB: Linear.

Materials:
 Body: Forged Brass (ASTM B283).
 Flow Optimizer: Noryl®
 Ball and Stem:
 Two-way: Nickel-chrome Plated Brass or 316 Stainless Steel.
 Three-way: Nickel-chrome Plated Brass.
 Stem Seals: EPDM O-rings.
 Ball Seals: Reinforced TEFLON™ Seals with EPDM O-rings.

Approvals/Standards:
 Valves: ANSI Class IV close-off/leakage (maximum 0.01% of C_v let by)
 Actuators: See literature for the given actuator.

Parts and Accessories:
 5112-11 replacement mounting kit for Honeywell direct coupled actuators.

® Registered Trademark of the General Electric Company
 ™ Registered Trademark of E I DuPont de Nemours

VBN2, VBN3 CONTROL BALL VALVES WITH THREADED CONNECTIONS

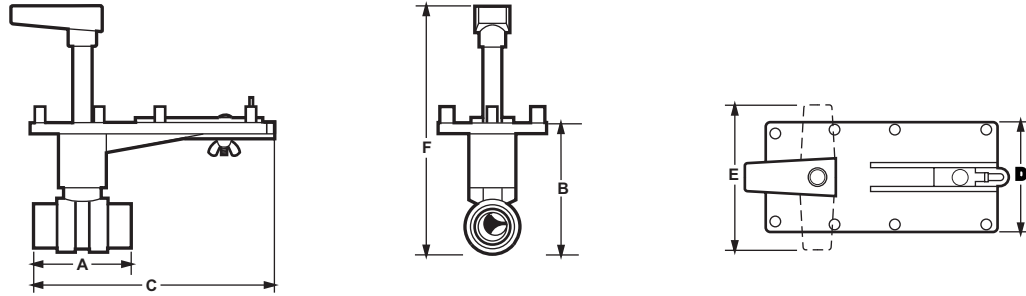

Pipe Size	Model No.	C _v	Dimensions inches (mm)						Weight lb (kg)
			A	B	C	D	E	F	
1/2"	VBN2A	0.38, 0.68, 1.3, 2.0, 2.6, 4.7, 11.7	2-3/8 (60)	3-7/16 (87)	6-5/8 (168)	3 (76)	4 (102)	8-1/8 (206)	1 (0.5)
		8.0	2-5/8 (67)	3-11/16 (94)	6-1/2 (165)	3 (76)	4 (102)	8-5/16 (211)	1 (0.5)
3/4"	VBN2B	0.31, 0.63, 1.2, 2.5, 4.3, 7.4, 14.7	2-3/8 (60)	3-7/16 (87)	6-7/16 (164)	3 (76)	4 (102)	8-1/8 (206)	1 (0.5)
		10.1, 29	2-5/8 (67)	3-11/16 (94)	6-1/2 (165)	3 (76)	4 (102)	8-5/16 (211)	1 (0.5)
1"	VBN2C	9.0	3-3/4 (95)	3-11/16 (94)	7-1/16 (179)	3 (76)	4 (102)	8-5/16 (211)	1 (0.5)
		4.4, 15.3, 54	3 (76)	3-15/16 (100)	6-3/4 (171)	3 (76)	4 (102)	8-11/16 (221)	1.4 (0.6)
		26, 44	4-3/8 (111)	4-7/16 (113)	7-3/8 (187)	3 (76)	4 (102)	8-7/8 (225)	2.4 (1.1)
1-1/4"	VBN2D	4.4, 8.3, 14.9, 25, 41	3 (76)	3-15/16 (100)	6-11/16 (170)	3 (76)	4 (102)	8-11/16 (221)	1.4 (0.6)
		37, 102	3-5/8 (92)	4-7/16 (113)	7 (178)	3 (76)	4 (102)	9-1/16 (231)	2.4 (1.1)
1-1/2"	VBN2E	23, 30, 74	3-3/8 (86)	3-15/16 (100)	6-15/16 (176)	3 (76)	4 (102)	9-1/16 (231)	2.4 (1.1)
		41, 172	3-3/4 (95)	5-3/16 (132)	7-1/16 (179)	3 (76)	4 (102)	8-7/8 (225)	3.2 (1.5)
2"	VBN2F	42, 108	4 (102)	5-3/16 (132)	7-3/16 (183)	3 (76)	4 (102)	8-7/8 (225)	3.2 (1.5)
		57, 71, 100, 210, 266	4-3/8 (111)	5-3/4 (146)	7-7/16 (189)	3 (76)	4 (102)	10-1/2 (267)	5 (2.3)
2-1/2"	VBN2G	45, 55, 72, 101, 162, 202	4-3/4 (121)	5-3/4 (146)	7-9/16 (192)	3 (76)	4 (102)	10-1/2 (267)	5.5 (2.5)
3"	VBN2H	49, 63, 82, 124, 145	5 (127)	5-7/8 (149)	7-11/16 (195)	3 (76)	4 (102)	10-11/16 (271)	5.9 (2.7)

M23550

Fig. 1. VBN2 dimensions in inches (millimeters).

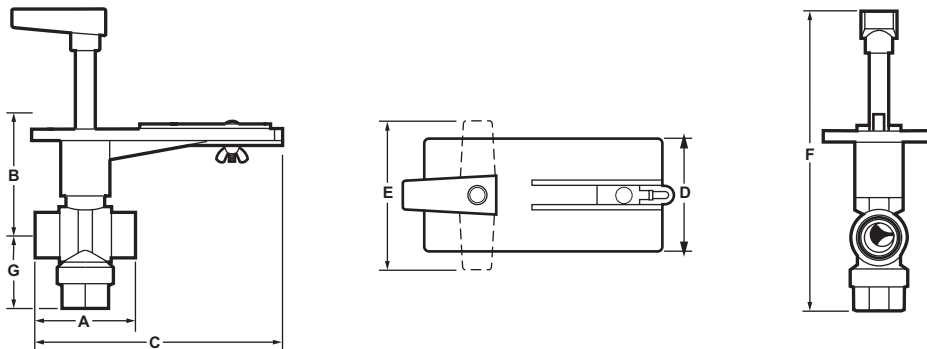

Pipe Size	Model No.	C _v	Dimensions inches (mm)							Weight lb (kg)
			A	B	C	D	E	F	G	
1/2"	VBN3A	0.33, 0.59, 1.0, 2.4, 4.3, 8.0	3-1/2 (90)	3-5/16 (84)	7 (178)	3 (76)	4 (102)	9-3/8 (238)	2-3/8 (60)	2.4 (1.1)
3/4"	VBN3B	0.40, 0.66, 1.3, 2.4, 3.8, 7.0, 11.0	2-13/16 (71)	3-5/16 (84)	6-1/2 (168)	3 (76)	4 (102)	8-13/16 (224)	2 (51)	2 (0.9)
1"	VBN3C	0.40, 0.65, 1.3, 2.3, 3.5	3-13/16 (97)	3-5/16 (84)	7-5/16 (186)	3 (76)	4 (102)	9-1/2 (241)	2-3/4 (70)	2.8 (1.3)
		8.6, 22	3 (76)	3-13/16	6-13/16 (173)	3 (76)	4 (102)	9-13/16 (249)	2-5/8 (67)	2.6 (1.2)
		4.5, 14.9, 31	4-1/2 (114)	4 (102)	7-13/16 (198)	3 (76)	4 (102)	10-13/16 (275)	3-1/4 (83)	3.3 (1.5)
1-1/4"	VBN3D	4.1, 8.7, 19.0	3 (76)	3-13/16	6-13/16 (173)	3 (76)	4 (102)	9-13/16 (249)	2-1/2 (64)	2.5 (1.1)
		12.7, 27, 34	3-5/8 (92)	4 (102)	7-5/16 (186)	3 (76)	4 (102)	10-5/16 (262)	2-3/4 (70)	2.8 (1.3)
1-1/2"	VBN3E	4.0, 8.3, 13.4, 32	4-1/2 (114)	4 (102)	7-13/16 (198)	3 (76)	4 (102)	10-13/16 (275)	3-1/4 (83)	3.3 (1.5)
		24, 61	4 (102)	4-1/2 (114)	7-5/16 (186)	3 (76)	4 (102)	11 (279)	3-1/4 (83)	3.3 (1.5)
2"	VBN3F	24, 38, 57	4 (102)	4-1/2 (114)	7-5/16 (186)	3 (76)	4 (102)	11 (279)	3-1/4 (83)	3.3 (1.5)
		83, 109	5 (127)	5-13/16	7-13/16 (198)	3 (76)	4 (102)	12-5/16 (313)	3-3/4 (95)	3.8 (1.7)
2-1/2"	VBN3G	38, 74, 100	5 (127)	5-13/16	7-13/16 (198)	3 (76)	4 (102)	12-5/16 (313)	3-3/4 (95)	3.8 (1.7)

M23551

Fig. 2. VBN3 dimensions in inches (millimeters).

Table 2. Two-Way C_V Values.

	C _V Designator																	
	B	D	E	F	G	H	J	K	L	M	N	P	R	S	T	U	1	2
1/2"	0.38	0.68	1.3	2.0	2.6	4.7	8.0	11.7 ^a										
3/4"	0.31	0.63	1.2		2.5	4.3	7.4	10.1	14.7 ^a	29 ^a								
1"						4.4	9.0		15.3	26	44 ^a	54 ^a						
1-1/4"						4.4	8.3	14.9	25	37	41 ^a			102 ^a				
1-1/2"									23	30	41		74				172 ^a	
2"											42	57	71	100	108 ^a		210	266 ^a
2-1/2"											45	55	72	101		162	202 ^a	
3"											49	63	82		124	145 ^a		

^a Denotes full port valve (with no insert). Provides linear flow control.

Table 3. Three-Way C_V Values.

	C _V Designator														
	B	C	D	E	F	G	H	J	K	L	M	N	P	R	S
1/2"	0.33	0.59		1.0	2.4		4.3	8.0							
3/4"		0.40	0.66	1.3	2.4	3.8		7.0	11.0 ^a						
1"		0.40	0.65	1.3	2.3	3.5	4.5	8.6	14.9	22	31				
1-1/4"							4.1	8.7	12.7	19 ^a	27	34 ^a			
1-1/2"							4.0	8.3	13.4	24	32 ^a		61		
2"										24		38	57	83	109
2-1/2"												38		74	100 ^a

^a Denotes full port valve (with no insert). Provides linear flow control.

NOTE: When valves are mounted between pipe reducers, there is a decrease in actual valve capacity because the reducers create additional pressure losses in the system. This is especially true for ball valves because of their high capacity.

Rangeability

Rangeability is a measure of a valve's controllability (sometimes referred to as its Turndown Ratio). Rangeability is a measured property and is expressed as the ratio of a valve's maximum flow rate to its minimum controllable flow rate.

Table 4. Rangeability of two-way actuated ball valves

Valve Size	Cv	Rangeability
1/2"	0.38	41
	0.68	17
	1.3	52
	2.0	*
	2.6	321
	4.7	159
	8.0	390
	11.7	251
3/4"	0.31	41
	0.63	17
	1.2	52
	2.5	321
	4.3	159
	7.4	*
	10.1	390
	14.7	251
1"	29	1503
	4.4	159
	9.0	390
	15.3	1040
	26	484
1-1/4"	44	1263
	54	1207
	4.4	159
	8.3	390
	14.9	1040
	25	*
	37	484
1-1/2"	41	1207
	102	1263
	23	484
	30	*
	41	603
2"	74	1263
	172	558
	42	603
	57	*
	71	287
	100	*
	108	558
	210	750
2-1/2"	266	877
	45	250
	55	*
	72	287
	101	558
	162	750
202	877	

* Data not available at time of printing

Valve Size	Cv	Rangeability
3"	49	250
	63	287
	82	558
	124	750
	145	877

* Data not available at time of printing

Effective Cv

For effective Cv's for Honeywell control ball valves when used with pipe reducers, refer to the Product Data sheet form no. 62-2648.

Application Notes

IMPORTANT

Valve sizing is important for correct system operation. Undersized valves do not have sufficient capacity at maximum load. Oversized valves do not have sufficient authority over the load in modulating applications.

Oversized valves can cause excessive cycling and the seat and ball can be damaged because of the restricted opening.

Proper Use

These valves are only for use in cold, warm, hot water systems and for steam applications. They are designed for a medium temperature range of from 35 to 250°F, at a maximum pressure of 360 psig VBN valves are to be operated with the appropriate Honeywell direct coupled actuators only.

Water should be properly filtered, treated and conditioned according to local conditions and the recommendations of the boiler or chiller manufacturers. The installation of a strainers and filters is recommended.

IMPORTANT

The presence of excessive iron oxide (red rust) in the system voids the valve warranty.

Required Operating Torque

Both Honeywell non-spring return and spring return low torque direct coupled actuators can be utilized with the VBN2 and VBN3 valves. VB valves use a patented seat design that reduces the torque needed from the actuator. A 35 lb-in. DCA provides sufficient torque to close the valve at rated close-off. (See Table 6.) These ratings exceed most HVAC application requirements.

Table 5. Close-off, Differential Pressure Ratings.

Valve Type	Valve Size	Close-off Pressure Rating (psi)
2 way	1/2", 3/4"	130
	1", 1-1/4", 1-1/2", 2", 2-1/2", 3"	100
3 way	1/2", 3/4", 1"	50
	1-1/4", 1-1/2", 2", 2-1/2"	40

NOTE: 3-way close-off ratings apply to 3-way valves with the B port plugged

TYPICAL SPECIFICATIONS

Ball Valve

Valve housing shall consist of forged brass rated at no less than 360 psi at 250°F. Standard valve ball shall consist of chemically nickel-plated brass. Manufacturer shall be able to provide optional 316 stainless steel ball and stem for two-way valves. Valve shall have a blow-out proof stem with two EPDM O-rings with minimum 600 psi rating. Manufacturer shall be able to provide glass-filled polymer ball insert to make flow control equal percentage. Valves shall be Honeywell. Two-way valves shall have EPDM O-rings behind ball seals to allow for a minimum close-off pressure of 100 psi with actuator which provides 35 lb-in. torque for 1/2 to 3 inches sizes. Valve shall be available with a minimum of 53 unique C_V values. Valve shall be available with threaded (FNPT) end connections. Three-way valves shall be installed in a "T" configuration with actuator perpendicular to shaft. Valve shall not require elbows of any kind. Three-way valves shall have EPDM O-rings behind ball seals to allow for a minimum close-

off pressure of 40 psi with an actuator that provides 35 lb-in. torque for 1/2 to 2-1/2 inches sizes. Three-way valves must be available in both mixing and diverting configurations and shall be available with a minimum of 42 unique C_V values. Valve shall be available with threaded (FNPT) end connections.

Valve Actuator

Control valve actuator shall accept analog modulating [(0)2-10 Vdc], floating (tri-state), or two-position signal as indicated in the control sequence. Actuators shall be by Honeywell. Actuator shall provide minimum torque required for full valve shutoff position. Wiring terminals shall be provided for installation to control signal and power wiring.

Actuator shall be available with housing suitable for outdoor installation.

Accessories Identification tags shall be available for all valves; tags shall be indelibly marked with C_V , model number, and tag location.

Automation and Control Solutions

Honeywell International Inc.
1985 Douglas Drive North
Golden Valley, MN 55422
customer.honeywell.com

Honeywell Limited-Honeywell Limitée
35 Dynamic Drive
Toronto, Ontario M1V 4Z9

© U.S. Registered Trademark
© 2006 Honeywell International Inc.
62-3077 C.H. 09-06



Printed in U.S.A. on recycled
paper containing at least 10%
post-consumer paper fibers.

Honeywell